



REPAIR MANUAL

COMMUNICATIONS
HF TRANSMITTER

MODEL
HT-44

WDØGOF Walt Cates

WDOGOF

**+SUPPLEMENT
TO
OPERATION AND MAINTENANCE
MANUAL
HALLICRAFTERS
HT-44**



**SUPPLEMENT TO
OPERATION AND MAINTENANCE MANUAL
HALLICRAFTERS HT-44**

INTRODUCTION

The HT-44 production started in 1962. It is a 17 tube AM-CW-SSB transmitter/exciter covering 80 through 10 meters. The power output is 100-130 watts PEP SSB, 100-130 watts CW and 25 to 35 watts AM. The features include VOX, CW break in, PTT, AALC and front panel control of slave (tranceive) or independent transmitter when used with the companion SX-117.

Over the years technical data on this system has scattered to the four winds. The purpose of this document is to assemble as much technical information as can be found into one clear and easy to read document. We will take a systematic approach to the repair and restoration process. The prime assumption will be that nothing works and will proceed from there.

This document is available free of charge and can be downloaded from the Hallicrafters users' group <https://groups.io/g/HallicraftersRadios> or <https://wd0gof.com> . This document is the intellectual property of the author, Walter A. Cates, WDØGOF. Unless specifically credited to a contributor all processes, ideas, drawings, data sheets and opinions contained here are those of the author.

Special thanks to Bernie, WDØGMD for the loan of his HT-44 for test and research for writing this document.

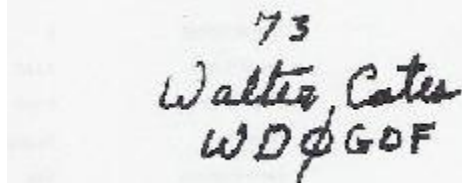

73
Walter Cates
WDØGOF

**SUPPLEMENT TO
OPERATION AND MAINTENANCE MANUAL
HT-44**

Contents

INTRODUCTION.....	4
1, REPAIR AND REFURBISHING.....	8
1-1, RECAPPING.....	8
1-2, AFTERMARKET MODIFICATIONS.....	8
1-3 TEST EQUIPMENT REQUIRED.....	8
1-4, INITIAL POWER UP.....	9
1-4-1, VOLTAGE VERIFICATION TESTS.....	10
1-4-2, INITIAL BIAS ADJUSTMENT.....	10
1-5, OSCILLATORS.....	10
1-5-1 CARRIER OSCILLATOR TEST AND VERIFICATION.....	10
1-5-1-1, CARRIER OSCILLATOR FAULT ANALYSIS.....	11
MODE / VOLTAGE CHART.....	11
1-5-2 HETRODYNE OSCILLATOR.....	11
HET OSC VOLTAGE CHART.....	11
1-5-3 VFO.....	11
1-5-3-1 VFO TEST AND ALIGNMENT.....	12
VFO VOLTAGE CHART.....	12
1-6, DRIVER/PA PRETEST & SETUP.....	13
1-6-1, DRIVER & PA PRESET.....	13
1-6-2, 6.5 MHZ TRAP.....	13
1-7 FIRST MIXER, 6-6.5MHz I.F., SECOND MIXER.....	14
1-7-1, MIXER/I.F. SETUP & ALIGNMENT.....	14
1-7-1-1, INJECTION LEVEL PRETEST.....	14
1-7-1-2, 6MEG ALIGNMENT.....	14
MIXER/IF VOLTAGE CHART.....	14
1-8 DRIVER / PA ALIGNMENT.....	15
1-8-1, DRIVER/PA COIL ADJUSTMENTS.....	15
1-8-2, 10 METER ADJUSTMENT.....	16
1-8-3, 15 METER ADJUSTMENT.....	16
1-8-4, 20 METER ADJUSTMENT.....	16

1-8-5, 40 METER ADJUSTMENT.....	16
1-8-6, 80 METER ADJUSTMENT.....	16
1-9, PA NEUTRALIZATION.....	16
1-9-1, NEUTRALIZATION PRE-TUNE	17
1-9-2, NEUT. SET UP.....	17
1-10, CARRIER DRIVE LEVEL	17
1-10-1 CARRIER LEVEL ADJUSTMENT.....	18
1-11, MODULATION AND CARRIER SUPPRESSION.....	20
1-11-1 AUDIO PHASE BAL AND AUDIO BAL PRESET TEST	20
1-11-2 CARRIER PHASE ADJUSTMENT.....	21
1-11-3 CARRIER SUPPRESSION TEST AND ADJUSTMENT	21
1-11-4 UNWANTED SIDEBAND REJECTION	22
2 SUBSYSTEM ADJUSTMENT & TROUBLE SHOOTING.....	23
2-1 MICROPHONE AUDIO	23
2-1-1, VOLTAGE CHART.....	23
2-1-2, SIGNAL LEVEL CHART	23
2-1-3, REFERANCE VOLTAGES	23
2-2, VOX TEST AND TROUBLESHOOTING.....	24
2-2-1, VOX TEST SETUP	25
2-2-2, VOX TEST.....	25
2-2-2-1, VOX SIGNAL & VOLTAGE MEASURMENTS	25
2-2-3, ANTI-TRIP	26
2-2-3-1 ANTI-TRIP TEST	26
2-2-4 DRIVER/PA TROUBLESHOOTING.....	27
2-2-4-1 STATIC DC VOLTAGES	27
2-2-4-2 SIGNAL DRIVE LEVELS	27
2-2-5 AALC.....	28
2-2-6, DRIVER TUNING SETPOINTS	28
2-2-7, GOING ON THE AIR WITH THE 44.....	29
2-2-7-1, BIAS ADJUSTMENT	29
2-2-7-2, PA OUTPUT FINAL ADJUSTMENT.....	29
3, ATTACHMENTS.....	30
3-1, ERRATA SHEET TUBE MATCHING.....	30
3-2, INTERNAL R/T RELAY MOD	31
3-3, DATA SHEETS	32

3-3-1 MIC AUDIO DATA.....	32
3-3-2, VOX SIGNAL & VOLTAGE MEASURMENTS.....	33
3-3-3, CARRIER OSC.....	33
MODE / VOLTAGE CHART.....	33
3-3-4 HET OSC	33
HET OSC VOLTAGE CHART.....	33
3-3-5 VFO.....	33
VFO VOLTAGE CHART.....	33
3-3-6, MIXER-IF	33
MIXER/IF VOLTAGE CHART	33
3-4 MISC.....	34
3-4-1, ANALYZER/SCOPE PICKUP	34

1, REPAIR AND REFURBISHING

This document is written with the assumption that the restorer has a basic understanding of circuit and tube theory. In **Section 1** you will find the test and alignment procedures. If a particular process does not function as described you will proceed to the appropriate subsection of section **2, SUBSYSTEM TROUBLE SHOOTING** for fault analysis. Section **3 ATTACHMENTS** contains additional information on the system and a subsection of data sheets. You can copy the data sheets to record data as you perform system analysis. A complete cleaning and mechanical inspection are always advised. Cleaning of the rotary switches and the relays is of particular importance. Go to <https://wd0gof.files.wordpress.com/2019/02/rig-cleaning.pdf> for the process I have used for 50 years. After a thorough cleaning do a close visual inspection. Look closely for broken or burned components. Check the rotation of the controls and mechanical stops of the main tuning dial. Try to eliminate the mechanical problems first. Inspect L28 for heat deformation on the end furthest from the chassis side panel. This is a high failure rate item when the rig is mistuned or misused.

1-1, RECAPPING

There is one dual section capacitor that is a must replace item. C91A and B can be replaced with custom made dual capacitors or two individual capacitors positioned under the chassis. Either way you should seek out very low ESR rated capacitors. ESR's of 0.5 ohm and lower are available. I prefer ESR of 0.05 or less. There is much discussion about the Plastic Mica and the Ceramic Tubular caps used in the 44. You must follow your heart here. I do not replace them unless I find a bad one.

1-2, AFTERMARKET MODIFICATIONS

It is rare to find a unit that has not been modified or "improved" by a previous owner. As a general rule you are better off stripping all the mods and returning the rig to its original condition.

1-3 TEST EQUIPMENT REQUIRED

- Dummy key plug (key plug with no connections).
- Dual trace scope, 100mhz BANDWIDTH min, 1X, 10X PROBES.
- Spectrum Analyzer HIGHLY RECOMMENDED.
- Two multimeters, no need to spend a lot of money here. One small VOM with a 2.5 vdc and 10vdc range dedicated to plate current setup and monitoring. The second meter can be a Harbor Freight \$6 - \$10 DVM.
- Frequency counter, 1.6 – 40MHz
- Dynamic microphone, see <https://wd0gof.com/hallicrafters-radio/technical-discussions/ht/ht-miscellaneous/> and click on SR & HT SERIES MIC SELECTION.
- Telegraph key
- Hf Signal generator
- Dummy load/wattmeter
- Microphone patch cable
- Tube capacitive pick-up (see 2-2-4)



As a general rule I have tried to eliminate specialized or expensive test equipment. Systems like the HT-44 cause me to make acceptance. The phasing adjustments of the balanced modulators as described in the manual can be quite tedious. When you have completed the process all you really know is that you have completed the process. A spectrum analyzer turns the 10minute to ½ hour process into a minute and a half process with definitive, measurable results. Do not get carried away with features. Center frequency 7.23MHz, bandwidth 0.3KHz and 0.5KHz/division. Search eham and qrz classified ads.

1-4, INITIAL POWER UP

First and of critical importance, you must have a power supply that has been tested and meets all the original specifications. NOTE: The actual B+, high voltage and negative bias voltages measured in your system will vary from the values on the schematic and in this document. **The AC input voltage must be from 105 to 125vac.** A 5v change in the AC voltage will equate to about a 20vdc difference in the high voltage, 10vdc in the B+ and about 5vdc change in the bias voltage. The voltages measurements in this document relate to 122vac bench supply. You will need a dedicated voltmeter plugged into the test jacks in the rear of the PS-150 to monitor plate current. It will remain there throughout all testing. It will need 2.5v full scale and 5 or 10v full scale switch positions. Remove the top and bottom covers of the HT-44. Remove the case.

BE AWARE, from this moment on you are exposed to LETHAL HIGH VOLTAGE.

Unless otherwise noted the **turn on preset conditions** will be:

- VFO SELECTOR ----- XMTR
- MIC GAIN ----- Ø
- RF LEVEL ----- Ø
- FINAL TUNING ----- center of 40-meter bar.
- DRIVER TUNING ----- center of 40-meter bar.
- BAND SELECTOR ----- 7.0
- VFO DIAL ----- 230
- FUNCTION ----- AM
- OPERATION ----- STBY
- DELAY ----- full counterclockwise
- CAL LEVEL ----- full counterclockwise
- CAL RESET ----- center of its rotation
- NORM/XCVE (slide switch on rear of chassis) ---- NORM
- ANTENNA ----- connected to wattmeter/dummy load

NOTE: Throughout all testing when powered up, OPERATION in MOX position and FUNCTION in the AM position is the “safe” mode. There should not be any plate current in the PA final tubes. Any time you are not performing a specific test the equipment should be in the “safe” mode.

Before turn on:

Locate and become familiar with the following, R124, 5k 10w, pin 11 of S1 (VFO SELECTOR should be a solid white wire). Remove the PA cover.

**CAUTION YOU WILL BE EXPOSED TO LETHAL VOLTAGES.
OBSERVE THE FREE HAND RULE, THAT IS FREE HAND IN HIP
POCKET WHILE TAKING MEASUREMENTS. YOU COULD DIE.**

NOTE: The PS-150 power supply voltages normally run much higher than original documents and schematics indicate. I suspect this was true when the radios were new. A clue can be found on the voltage chart figure 12 in the original factory manual. You will note the screen voltage with the PA tubes cut-off was charted as 285vdc. That would have been with the AC input at 117vac. My bench power runs 123vac. The nominal voltages for the PS-150-120 power supply on my bench are: The +250vdc runs +305vdc. The -125vdc runs -150vdc. The +575vdc runs 680vdc. The +150vdc should be 150vdc +/- 2vdc. Throughout this document I will use the values as documented in the original manual.

1-4-1, VOLTAGE VERIFICATION TESTS

We are now going to measure the B+ 250vdc, the regulated 150vdc, the High Voltage 575vdc and measure and preset the bias voltage. This will be a no-load condition and the voltages will read 5 to 10% high.

Insure all the cable connections are correct. Turn the OPERATION SWITCH to MOX. There should be no indication of plate current on the meter monitoring the power supply.

The end of R124 connected to the terminal strip should measure $\approx +250\text{vdc}$

The end of R124 connected to V11 pin 5 should measure 150vdc +/- 2.0vdc

The metal strip the tube plate parasitic suppressors connect to should measure $\approx +575\text{vdc}$

Tab 11 of S1 should read a negative voltage. Adjust R206 (BIAS ADJUST) on the rear of the power supply for the maximum negative voltage it should read $\approx -125\text{vdc}$. We will leave it at the max setting for now. If these voltages are ok power down. Replace the PA cover. Since you are using a known to be good power supply, the absence of one of these 4 voltages would most likely indicate a wiring fault which needs to be cleared before you can proceed.

1-4-2, INITIAL BIAS ADJUSTMENT

Insure all the controls and switches meet the **turn on preset “safe” conditions**. Turn the OPERATION switch to MOX and allow 10 minutes for warm up. Turn the FUNCTION switch to CW and adjust the BIAS ADJ on the power supply for 1v on the meter connected to the power supply test jacks. One volt reflects 100ma of idle current. Return the FUNCTION switch to AM. If this procedure was successful, you are ready to proceed to the oscillator test procedures. If you are unable to set the idle current then the PA final tubes are bad or the grid, screen or plate voltage is missing. See figure 12 in the factory manual for aid in isolating this fault.

1-5, OSCILLATORS

There are three oscillators in the system, the carrier oscillator, the heterodyne oscillator and the VFO.

The frequency syntheses = Het osc – (carrier osc + VF0) = output frequency.

1-5-1 CARRIER OSCILLATOR TEST AND VERIFICATION

The carrier oscillator is one half of V1. Power up in the “safe” mode. While waiting 10 minutes for warm-up locate the junction of R5 (56 ohm) and R6 (220 ohm). Connect the scope using a 10X probe to the junction of R5 and R6. When the unit has warmed up move the FUNCTION switch to CW. You should see approximately 3vpp of 1650KHz on the scope. Adjust T1 for max signal. Move the probe from the scope to the frequency counter. Adjust C1 for exactly 1650KHz. Return to AM mode. Move the probe back to the scope. Connect a microphone and key the mic, you should see carrier on the scope when the mic is keyed. Return the controls to the “safe” mode. Plug the telegraph key into the key jack on the rear panel. Turn the OPERATION switch to VOX and set the FUNCTION switch to CW. When you press the key, you should see carrier on the scope. Rotate the DELAY control CCW press and release the key and note the fast dropout of the carrier osc. Rotate the DELAY fully clockwise press and release the key note a delay in drop out of approx. 1 second. Return all controls to the “safe” mode. Return the DELAY and CAL LEVEL to the full ccw position.

CRITICAL INFORMATION: At this point jump ahead to read section 1-10 and keep that information in mind as you go through the rest of the rehab process. The T2 adjustment will need to be corrected many times as you progress.

This completes the carrier oscillator tests. You have now proven the operation of the carrier oscillator and most of the function and operation switch functions.

1-5-1-1, CARRIER OSCILLATOR FAULT ANALYSIS

If the equipment failed the tests in 1-5-1 the following measurements should aid in fault analysis. Otherwise, continue to 1-5-2.

Setup in “safe mode”.

You will be making measurements at the junction of R1 and R2, the bottom of R2, and V1 pin1, pin2 and pin3. To get accurate measurements you must ensure that your meter does not load the oscillator. Connect the scope to the junction of R5 and R6 and observe the signal. Move the FUNCTION switch to CW. Now touch pins 1, 2, and 3 with the meter probe while observing the signal on the scope. If the probe causes a significant change in the amplitude of the signal you need a better meter.

MODE / VOLTAGE CHART

OPERATION	FUNCTION	R1 – R2	R2 bottom	V1pin1	V1 pin2	V1 pin3
MOX	AM	-138vdc	-140	265vdc	-130vdc	0.0vdc
MOX	CW	-1.4vdc	0.0vdc	199vdc	0.0	3.0vdc

Notes: Some schematics have R2 listed as C2. Voltages will differ from rig to rig. In the rig used for these readings the 250vdc measured 313vdc, the bias measured -140vdc.

1-5-2 HETERODYNE OSCILLATOR.

The Het Osc is comprised of V15 and its associated circuitry. V15A is the oscillator section and V15B is the cathode follower/buffer. This oscillator is the most troublesome of the three. There are no adjustments to pull the frequency of each xtal. So, if you do not have a box of spare xtals you are rather limited in what you can do to put it precisely on frequency. First thing, check the oscillator output. Connect the scope to the tie point of C121 and L31 which are located in the cathode ckt of V15B. The minimum peak to peak voltages for each band should be: 80 meters 3.75 Vpp, 40 meters 2.5 Vpp, 20 meters 2.5 Vpp, 15 meters 1.5 Vpp, 10 meters (all 4 segments) 1.5 Vpp.

If all the bands are off frequency in one direction you can offset some of the error with the carrier oscillator. The frequency synthesis is: TX frequency = (Het osc) – (carrier osc + VFO). If all the bands are high by say 500Hz then adjust the carrier osc to 1650.5KHz and you are good to go.

HET OSC VOLTAGE CHART

FUNCTION	OPERATION	V15					
		PIN 1	PIN 2	PIN 3	PIN 6	PIN 7	PIN 8
MOX	AM	144	0	0	302	57	53

1-5-3 VFO

The VFO is comprised of V10 A & B and associated circuitry. If it has stability problems most likely the fault is C27, 15pf N220 and C28, 51pf N80 the temperature compensating capacitors. V10A is the oscillator section and V10B is the buffer, cathode follower. This is an extremely stable oscillator design, if it drifts it has a fault. Find the failed component and replace it. Do not try to “modify stability into it”.

1-5-3-1 VFO TEST AND ALIGNMENT

SETUP:

Connect frequency counter to the switch side of C17 using a 10x scope probe. Preset C29 to the center of its tuning range. Adjust the CAL RESET to center of its rotation.

Turn the OPERATION switch to MOX.

Turn the FUNCTION switch to AM mode.

Allow 30 minutes warm-up/stabilize time.

INITIAL PRESET.

Tune the main tuning dial to 300.

Adjust L4 for a reading of 4.550MHz on the frequency counter.

FINAL TRACKING ALIGNMENT.

Tune the main tuning to 100 and adjust C29 for 4.750MHz on the counter.

Tune the main tuning to 400 and adjust L4 for 4.450MHz on the counter.

NOTE: These two adjustments interact, you may have to go back and forth, under or over correction at one or the other end to get both ends correct.

FINAL TRACKING CHECK

MAIN TUNING	FREQUENCY
0	4.850MHz
100	4.750MHz
200	4.650MHz
300	4.550MHz
400	4.450MHz
500	4.350MHz

Move the scope probe from the frequency counter to the scope

Set the main tuning to 250.

Adjust L2 for max signal. This signal should exceed 0.500 vpp.

Turn main tuning from 250 to 500 then to 0. The signal should not drop more than 0.075 volts at either end.

This completes the VFO tests and adjustments. This oscillator is a very good design. If it will not align or produce the proper signal level output there is a failed component the circuit does not need to be redesigned. You need to find the failed component.

VFO VOLTAGE CHART

OPERATION	FUNCTION	V10						
		PIN 1	PIN 2	PIN 3	PIN 6	PIN 7	PIN 8	PIN 9
MOX	AM	141vdc	0	86	141*	0	4	0

*Measured at junction of L2 & R24

1-6, DRIVER/PA PRETEST & SETUP

In order to properly test and analyze the audio, phasing and I.F. circuits properly the driver and PA need to be at or near normal. The 6DQ5 final tubes must be a matched pair. If you are unsure of the conditions of the final tubes proceed to section 3-1, **ERRATA SHEET TUBE MATCHING** and follow the instructions.

1-6-1, DRIVER & PA PRESET

Read through the following procedure to insure you understand all of the instructions before you start the operations.

Set the switches and controls to the “SAFE” configuration. Attach a microphone. Set the band switch to 40-meter band. Ensure MIC GAIN and RF LEVEL are set to zero. Set the signal generator to 7.23 MHz and max signal out. (output must be greater than 100,000uv). Using the 1X probe inject the signal from the generator into pin 2 of V8 (SECOND MIXER). Ensure the test meter is connected to the test jacks in the rear of the power supply. Preset the DRIVER TUNE and the FINAL TUNE for the center of the 40m bar.

Connect wattmeter and dummy load to transmitter output.

- Watching the plate current on the test meter and the power out on the wattmeter, key the mic.
- **Throughout this process do not key the mic for more than 3 to 4 seconds at a time**
- If you have power out adjust the drive from the signal generator for 35 to 50 watts. Keep adjusting the generator to maintain the output at 35-50 watts throughout this process.
- If there is low or no power out observe the plate current and adjust the DRIVER TUNE for a plate current peak.
- Once the driver is peaked adjust the FINAL TUNE for a **dip** in plate current.
- Adjust L8 and L18 for max power out.

If you are unable to get a minimum of 35 watts out then you have a fault in V8, 9, 16 or 17, or their associated circuitry. See section 2-2-4 DRIVER/PA TROUBLESHOOTING. This fault must be cleared before proceeding see section 2-2-4.

1-6-2, 6.5 MHZ TRAP

NOTE: This is the final adjustment for the 6.5meg trap.

With the equipment set-up as in 1-6-1 above, set the signal generator to 7.00 MHz. Key the mic and adjust the DRIVER TUNE and the FINAL TUNE for max power at 7.00 MHz. Readjust the output of the signal generator to maintain 35-50 watts output.

- Readjust the generator for 6.25MHz.
- Key the mic.
- DO NOT readjust the DRIVER TUNE or the FINAL TUNE.
- Adjust L11 (6.5MHz TRAP) for **MINIMUM** power out.

Note: Once you get the power output below 5 watts out you can connect the scope via a 10X probe to the tie-point of L29 and C106 for a more precise setting of L11

If you cannot null the 6.5MHz then either L11 or C59 is at fault. This completes the driver/PA pretest and setup.

1-7 FIRST MIXER, 6-6.5MHz I.F., SECOND MIXER

The first mixer, 6meg IF and second mixer train is composed of V6, T3, V7A, T4 and V8.

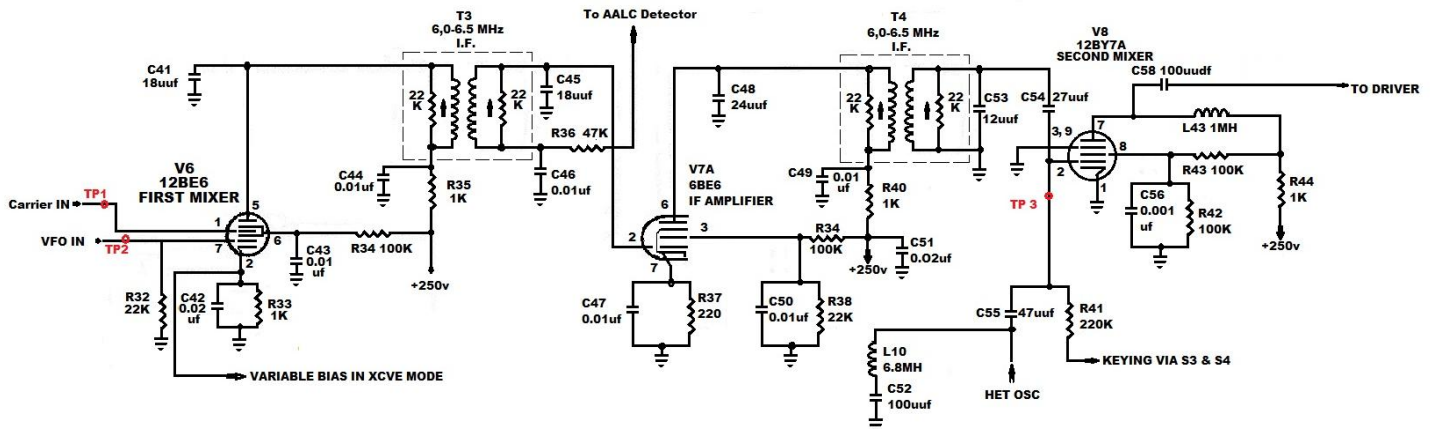

1-7-1, MIXER/I.F. SETUP & ALIGNMENT

Power up in safe mode. Allow 10 minute warm up.

Locate test points TP 1, TP 2 and TP3.

1-7-1-1, INJECTION LEVEL PRETEST

Set RF LEVEL to max.

Connect microphone.

Band switch to 7.0.

Connect the scope to TP1 pin 1 of V6. Key the mic and you should see 0.5vpp (from the carrier oscillator). If not Adjust T2 for 0.5vpp.

Connect the scope to TP2 pin 7 of V6. You should have 0.5vpp constant (from the VFO). If this signal is not present there is a fault in S1 (VFO SELECTOR) or you made an error in the 1-5-3 section tests. Return there and correct the fault.

1-7-1-2, 6MEG ALIGNMENT

Connect the scope to TP3 pin 2 of V8. Set the VFO to 100 and adjust T3 and T4 top ends for max signal on the scope (approx. 1vpp). Tune the VFO to 400 and adjust T3 and T4 bottom ends for 1vpp signal.

Recheck at 100 and 400 on the dial and retune until both ends are the same you should have 1vpp +/- 0.3vpp.

MIXER/IF VOLTAGE CHART

V6		V7		V8	
PIN	VOLTAGE	PIN	VOLTAGE	PIN	VOLTAGE
1	0	2	0	2	-144/-0.5
2	1.0 *	3	83/73	7	317/276
5	317/277	6	1.1/0.9	8	158/57
6	61/53 *	7	317/274		
7	0				

Voltages with * will differ dependent upon band selection.

Measured in MOX, AM, RF LEVEL at max. first voltage **unkeyed**/second voltage **keyed**.

1-8 DRIVER / PA ALIGNMENT

The driver/pa alignment will be done CW mode with telegraph key plugged in. If you are unable to achieve the recommended power output, go to section 2-2-4. Return to this section when normal power output is achieved.

Throughout the driver / pa alignment you will need to constantly adjust the RF LEVEL to stay at 100 watts. Keep backing down on the RF LEVEL to insure you are seeing the true coil peaks. You may have to adjust T2 if you cannot get 100 watts.

Set up the controls to the “safe” configuration.

1-8-1, DRIVER/PA COIL ADJUSTMENTS

On each of the following bands preset the driver and final tuning controls to the center of their respective band segment markings (see figure below). Then tune the coils to these mechanical positions. If they will not tune up with the controls located as indicated on the front panel proceed to section 2 SUBSYSTEM TROUBLE SHOOTING, 2-2-6, DRIVER TUNING SETPOINTS. Return to this point when fault is cleared.



1-8-2, 10 METER ADJUSTMENT

Set the band switch to 28.5 tune the VFO to 750. Set the DRIVER TUNING per the photo above. Preset the FINAL TUNING in the same manner as you did the DRIVER TUNING. Key the transmitter and advance the RF LEVEL until you start to see a rise in plate current (on the meter attached to power supply monitor jacks). Adjust L5 and L15 for max plate current. Tune the FINAL TUNING for max power and observe the plate current. A plate current dip should occur in coincidence with, or very close to the power output peak. Double check the peak points on each coil and controls several times until there is no improvement. If you are unsuccessful getting proper power output proceed to 2-2-4 DRIVER/PA TROUBLESHOOTING. When you have corrected the fault return to this point.

1-8-3, 15 METER ADJUSTMENT

Set the band switch to 21. Set the VFO to 360 Set the DRIVER TUNING per the photo. Repeat the process used in 1-8-2 adjusting L6 and L16

1-8-4, 20 METER ADJUSTMENT

Set the band switch to 14. Set the VFO to 280 Set the DRIVER TUNING per the photo. Repeat the process used in 1-8-2 adjusting L7 and L17

1-8-5, 40 METER ADJUSTMENT

Set the band switch to 7. Set the VFO to 230 Set the DRIVER TUNING per the photo. Repeat the process used in 1-8-2 adjusting L8 and L18

1-8-6, 80 METER ADJUSTMENT

Set the band switch to 3.5. Set the VFO to 900 Set the DRIVER TUNING per the photo. Repeat the process used in 1-8-2 adjusting L9 and L19

1-9, PA NEUTRALIZATION

Neutralization is the process of nullifying the effect of direct grid to plate coupling of energy via the interelectrode capacitance between the plate and the grid. This process removes the DC drive and eliminates any gain factor in the PA. With PA gain eliminated any energy measured on the plate is a result of the plate to grid capacitive coupling. Our goal is to minimize this energy. It is correct when the PA power out peak and the PA plate current dip coincide.

1-9-1, NEUTRALIZATION PRE-TUNE

Power up in the safe mode. Set the band switch to 21. Set the VFO dial to 360. Set the RF LEVEL to 8. Switch to CW and adjust the DRIVER TUNE and FINAL TUNE for max power out. Reduce the RF LEVEL as needed to keep the power out at 45 - 65 watts. (You may have to peak L6 and L16 to get power peak.) Once you have tuned up **you will not readjust the DRIVER TUNE or the FINAL TUNE** throughout the rest of the neutralization process.

1-9-2, NEUT. SET UP

Power down the transmitter.

- Remove PA cover.
- Locate the wire connected to the base of the plate choke L27 and disconnect it. Tape the end of the wire or otherwise protect it from touching anything.
- Locate R77, 1.8K 1w resistor. Disconnect it at the terminal strip end.

The plate high voltage and the screen voltage have now been removed from the PA tubes. Power up in safe mode and ensure the RF LEVEL is at minimum. Allow enough warm up time to ensure the PA tubes are up to max temp. Connect the scope to ungrounded end of L29. Switch to CW and advance the RF LEVEL until you get good signal on the scope. Adjust C77 for minimum signal. Some advance of the RF LEVEL and the scope gain will be needed as you approach the null.

This completes the neutralization process. Power down and reconnect the high voltage and screen voltage.

1-10, CARRIER DRIVE LEVEL

The carrier oscillator ckts have enough drive to drive the transmitter to well over 200 watts. However, the audio phasing and modulation ckts are only designed to operate efficiently at the 100 to 130-watt level. It is critical that T2 be set to the proper level. T2 will require rechecking and readjustment repeatedly throughout the troubleshooting and alignment processes.

The following discussion concerns the T2 adjustments as set forth in the factory manual.

The HT-44 was designed to deliver 100 to 130 watts pep in SSB, 100 to 130 watts in CW and 25 to 35 watts in AM. It should be noted again, that the HT-44 is capable of being adjusted to 200 watts SSB/CW and 50 to 60 watts carrier in AM. However, the sideband generator and AM modulator are not designed to process that level of power.

There are those who use the HT-44 for CW only operation. They claim they adjust it for max power in CW mode and have had no problems with it. I have not analyzed that type of operation. I would assume that if the spurious and harmonic emissions stay with-in specifications it is feasible. This level of operation is well within the limits of the driver and finals. You might note the difference in 130watts and 160watts is 0.9db which is not even one S unit on the receiver end.

The readjustment of T2 will be required numerous times during trouble shooting and alignment processes. Keep in mind this adjustment should also be the *last thing repeated* before replacing the covers and putting the unit back in service.

Below, section 9-10 of the factory manual will appear in blue print and discussion notes will be in green print.

SECTION 1-10 CONTINUED:

The HT-44 was designed to operate with a dynamic, 600-ohm microphone. With a dynamic mic the normal setting of the MIC GAIN should fall between 3 and 6. The design of the front end of the mic amp train also took into consideration the use of a crystal microphone. The crystal microphone MIC GAIN setting will fall between 1 and 3. If the MIC GAIN setting fall outside these ranges, then some investigation of the mic or the mic amplifier ckt is indicated.

Amplified and “studio” microphones should not be used on the HT-44. The output on these microphones tend to peak in the 4000 to 6000 Hz range. In some cases, these mic outputs, at 4 to 6KHz, can be 4 to 8 db above 2500Hz. The HT-44 mic audio range is limited to 500 to 2500 Hz. **Over driving outside of the spec range of the audio circuits will cause spurious emissions and adjacent frequency interference.**

1-10-1 CARRIER LEVEL ADJUSTMENT

SECTION 9-10 (of the factory manual)

With the transmitter tuned to 14.25 MC (20-meter band) into a 50-ohm resistive dummy load, this transformer (T2) is adjusted to set the overall gain of the transmitter. Proceed as follows:

Connect an audio signal generator to the MIC connector (pin 1); ground pin 2 of the mic connector (do not apply the ground until all equipment is set up. Keep the duty cycle short), set the OPERATION switch to USB or LSB and the MIC GAIN control at maximum (10). Set the audio signal generator to 1000CPS and adjust the generator output level to approximately 3 millivolts RMS (8.4vpp). Detune the core of the balanced modulator output transformer (T2) so that the 3 millivolts of audio will produce 70 (98 watts) to 80 (128 watts) volts RF at the transmitter output (70 to 80 on the panel meter). The difference between 98 watts and 128 watts is 1.6db.

The standard output level for the dynamic, 600-ohm microphone is 5mvrms (.014vpp). So, with T2 set for 80vrms (128 watts) at 3 millivolts input, the likelihood is, that higher amplitude voice inflections of normal speech will produce envelope peak power in excess of 140watts.

NOTE: At this point, if you have followed the process as written all the major systems have been tested and proven. You are about to start the modulation and carrier suppression test and evaluation. There are components that have not been tested at this point. They are: V4, T7, and some switching functions of the FUNCTION and OPERATION switches. If you are not able to generate SSB power in the section 1-11 check V4, T7 and the switches. So far, we have worked around the VOX, ANTI-TRIP and AALC functions. Tests and adjustments of these subsystems are covered in section 2.

WDOGOF

1-11, MODULATION AND CARRIER SUPPRESSION

If you do not have a spectrum analyzer perform the tests and adjustments in sections 1-11-1 and 1-11-2. Then proceed to the tests described in the factory manual. These will be found in section 9-11, paragraphs 1 through 23. If at all possible, buy, beg or borrow a spectrum analyzer.

One day about 50 years ago while working on a Collins ARC/38A, I wanted to look at the spectrum on SSB and also monitor the mod envelope in AM. I had an old roller coil, 2" in diameter with 20 turns. I attach coax, BNC, T connector and attached to both the spectrum analyzer and the scope. I place the coil as close as I could to the PA assembly. It may be a little crude but it works fine to this day. See photo 3-4-1.

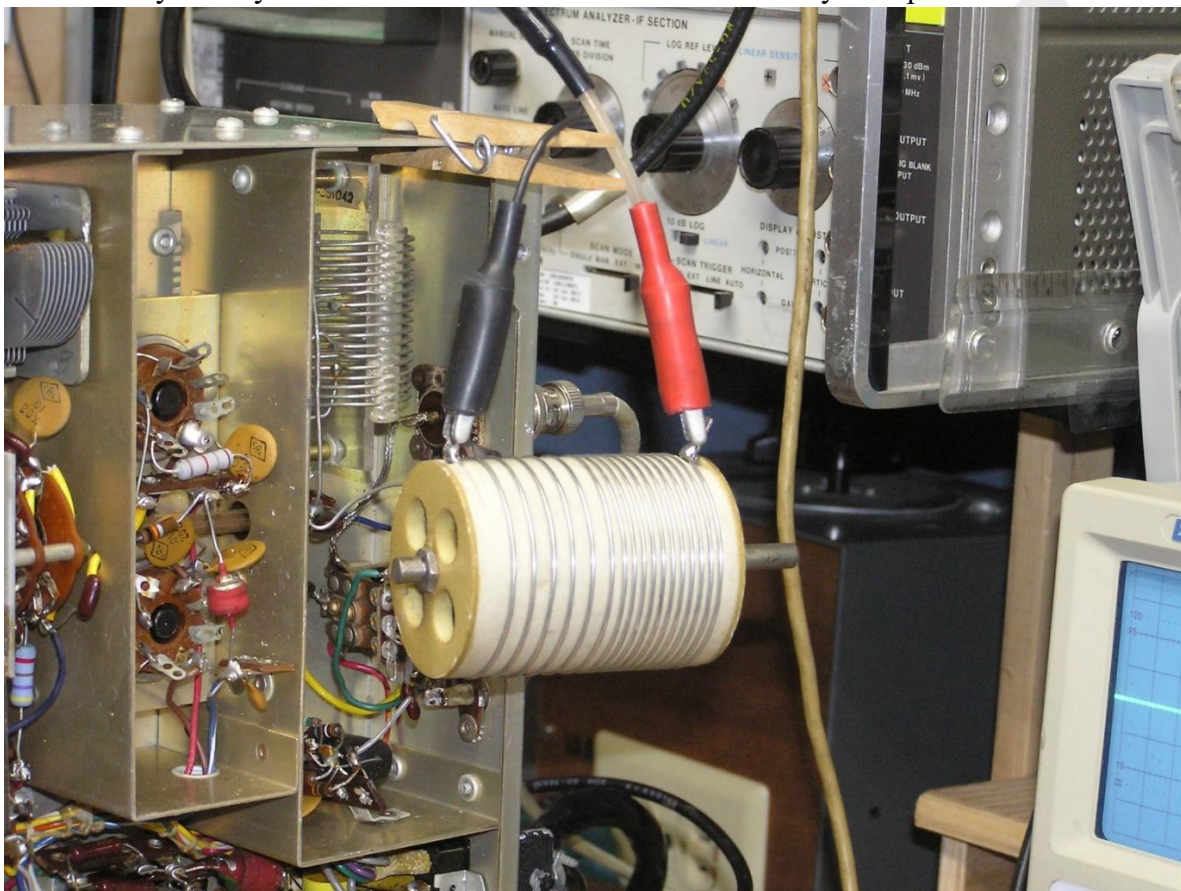

I can make AM observations switch to SSB or CW and make spectrum observations. Simple speedy.

1-11-1 AUDIO PHASE BAL AND AUDIO BAL PRESET TEST

THIS IS PRELIMINARY ADJUSTMENT; PRECISE ADJUSTMENT WILL FOLLOW.

Warm up unit in the safe mode.

- 1, Connect channel one of a dual trace scope to Pin2 of V5 and channel two to pin 7 of V5 using 10X 600v probes.
 - 2, Inject 5mv rms into pin 2 of the mic jack. Set the MIC GAIN to 8.
 - 3, Adjust the AUDIO Ø BAL control for a 90⁰ phase difference in the two signals.
 - 4, Move the probes to pins 1 and 6 of V5
 - 5, Adjust the AUDIO BAL control for equal amplitude signals.
- Repeat steps 3 to 5 until no further improvement is achieved. The signal level on pins 2 and 7 of V5 should be between 0.7 and 1.3vpp.

1-11-2 CARRIER PHASE ADJUSTMENT

THIS IS PRELIMINARY ADJUSTMENT; PRECISE ADJUSTMENT WILL FOLLOW.

Warm up unit in safe mode. Using 10X probes connect channel 1 of the scope to pin 7 of V3 and channel 2 to pin 2 of V4. Key-up in MOX, LSB with MIC GAIN at \emptyset or fully counterclockwise. Adjust L1 RF \emptyset and C6 RF \emptyset equal amplitude signals offset by 90°. The signal level should be from 2.5 to 3.2vpp.

1-11-3 CARRIER SUPPRESSION TEST AND ADJUSTMENT

Set up the 44 in the safe mode, power up and allow 15 minutes for warm up. The warm up is important, you must ensure all components are up to operating temperature.

Tune for max power at 7.32MHz, CW or AM.

- Connect mic patch cable, adjust audio oscillator for 5mv, 1000Hz.
- Set MIC GAIN to 8.
- Set function to LSB
- Set spectrum analyzer center freq to 7.23 MHz.
- Key the transmitter and adjust the CARRIER BAL controls R8 and R13 for minimum carrier signal.
- Unkey, switch to USB
- Key up, check carrier suppression adjusting R8 and R13 to test for min carrier.
- Go back and forth from USB and LSB to ensure carrier suppression is equal.
- Return equipment to “safe” mode.

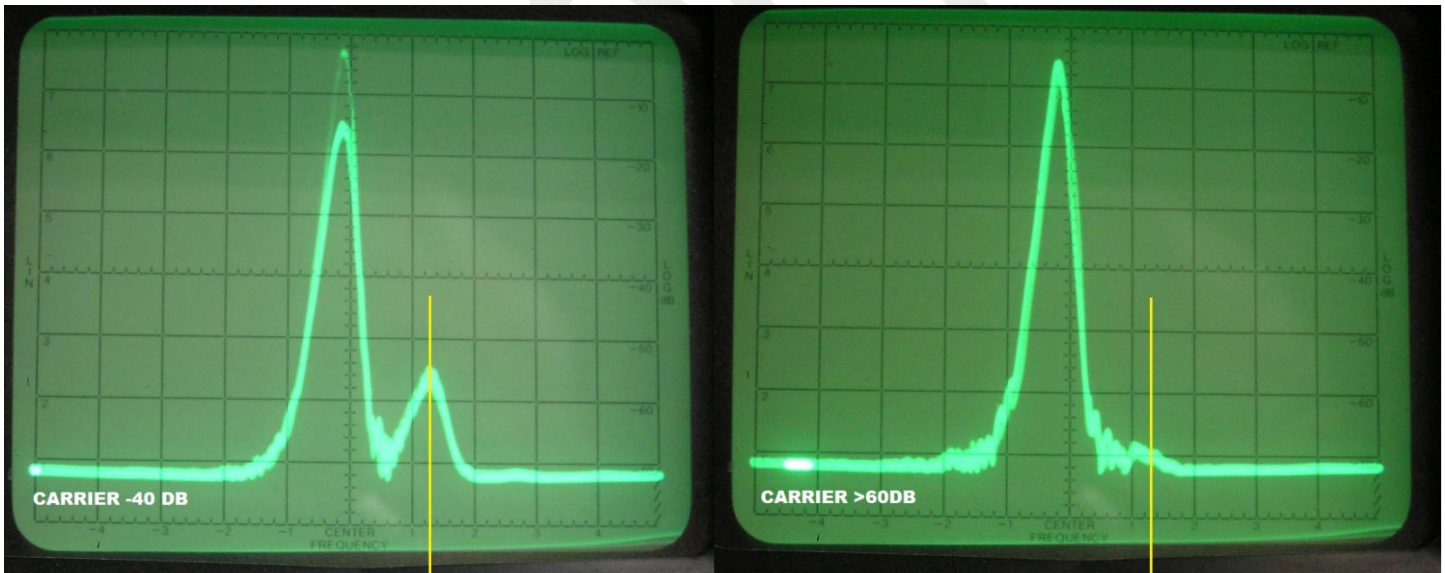

1-11-4 UNWANTED SIDEBAND REJECTION

Set up the 44 in the safe mode, power up and allow 15 minutes for warm up. The warm up is important, you must ensure all components are up to operating temperature.

Tune for max power at 7.23MHz, CW or AM.

1. Connect mic patch cable, adjust for 5mv, 1000Hz.
2. Set MIC GAIN to 8.
3. Set function to LSB
4. Set spectrum analyzer center freq to 7.23MHz.
5. Key the transmitter
6. Adjust the AUDIO Ø BAL and the AUDIO BAL controls for minimum USB signal.
7. Unkey, switch to USB
8. Key up, check LSB signal suppression, adjusting AUDIO Ø BAL and the AUDIO BAL controls for minimum. A slight tradeoff between USB and LSB may be required. But if the minimum setting for one or the other causes difference of more than 5db a fault has occurred. That fault is most likely a tube failure.
9. Return equipment to "safe" mode.
 - Repeat steps 1-5 adjusting RFØL and RFØC for max rejection of unwanted sideband.

Once again, a slight tradeoff between USB and LSB may be required. But if the minimum setting for one or the other causes difference of more than 5db a fault has occurred. That fault is most likely a tube failure.

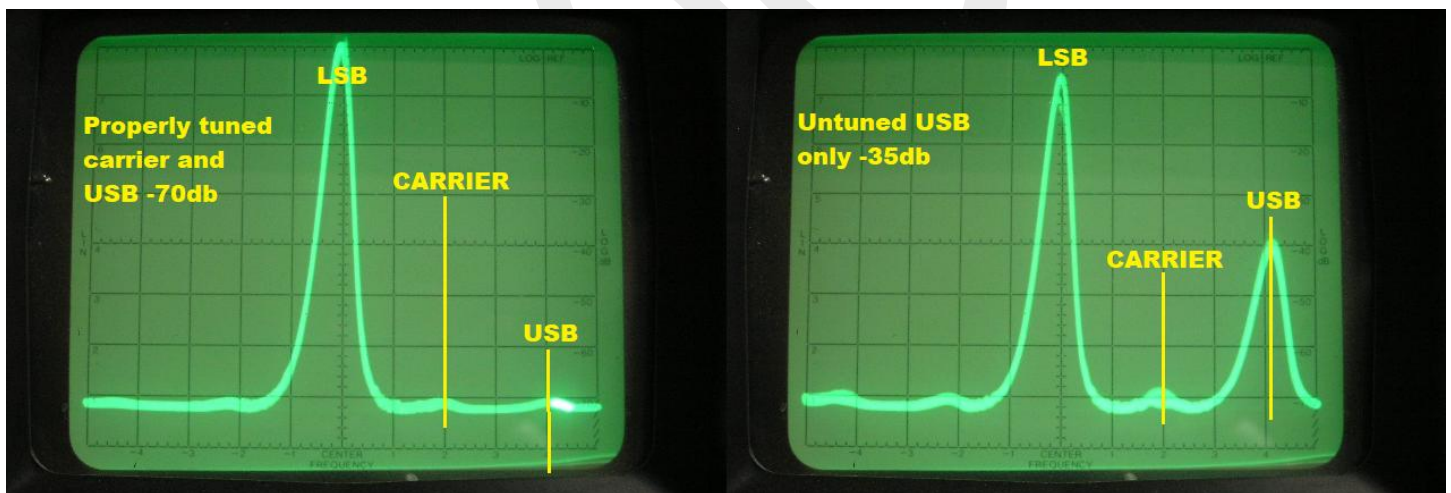

This completes the test and adjustments. Go to section 2-2-7, GOING ON THE AIR WITH THE 44.

2 SUBSYSTEM ADJUSTMENT & TROUBLE SHOOTING

2-1 MICROPHONE AUDIO

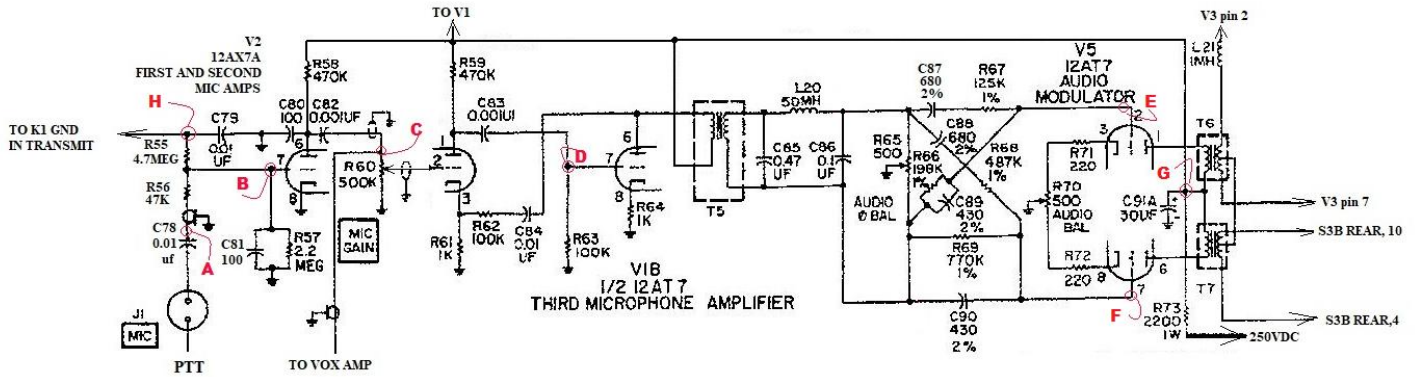

2-1-1, VOLTAGE CHART

NOTE: On the unit under test the +250-volt buss actually measured 315vdc. It is not uncommon for the 250vdc buss to run from 300 to 330vdc with AC line voltages between 120 and 124vac.

V2		V1B		V5	
1	57v/ (50v STBY)	6	260v/ (227 AM KEYED)	1	260V/ (227 AM KEYED)
2	0.0	7	0.0	2	0.0
3	0.34	8	2.6v/ (3.0v STBY)	3	2.0
6	60v/ (160 STBY)	/	////////////////////////////////////	6	260/ (227 AM KEYED)
7	-0.7v/ (140v CW)	/	////////////////////////////////////	7	0.0
/	////////////////////////////////////	/	////////////////////////////////////	8	2.0

2-1-2, SIGNAL LEVEL CHART

Inject 12mvpp, 1000Hz @ test point A.

Measurement taken in MOX, AM, mic keyed, MIC GAIN adjust for 90 to 95% modulation.

B	C	D	E	F
0.012vpp	0.39vpp	3.9vpp	1.0vpp	1.0vpp

2-1-3, REFERENCE VOLTAGES

Test point G

Test point H

2-2, VOX TEST AND TROUBLESHOOTING

Relay K1 provides the internal switching for the transmitter. Tube V13B is the control element for K1. V13B gets its turn on command from the PTT line **or** the VOX subsystem. When in the VOX mode a sample of the first mic amp (V2) output is fed to the VOX circuit (V12A and V13A). The VOX circuit sniffs this signal, rectifies it to create a DC voltage relative to the mic input signal. A voltage divider in the cathode of V14C which is connected to the grid of V13B sets up the quiescent off state for V13B. The DELAY control R90 sets this quiescent state and the delay in cutoff when mic audio is no longer present. This quiescent state can be triggered by rise in voltage on the grid of V13B or a lowering of the voltage on the cathode.

- In the VOX mode the mic signal amplified by V12A and V13A and rectified by V14C drives the grid of V13B into the on state thus energizing K1.
- The vox drop out delay is controlled by time constant of C112, R90, R89, R88 and the function and operation switches.
- When the OPERATION switch is in the MOX position S4A REAR pin 7 grounds any signal from the vox amp preventing the vox from controlling relay K1.
- In the CW function all the timing resistors are in the circuit providing the longest drop out time.
- When the FUNCTION switch is in AM, USB or LSB switch S3A REAR pin 9 places a gnd at the junction of R88 and R89 thus reducing the DELAY time constant for the voice modes.
- When the operation switch is in the MOX POSITION the PTT line is routed to the cathode of V13B. When the PTT line is grounded the reverse bias on the cathode is removed and V13B turns on.

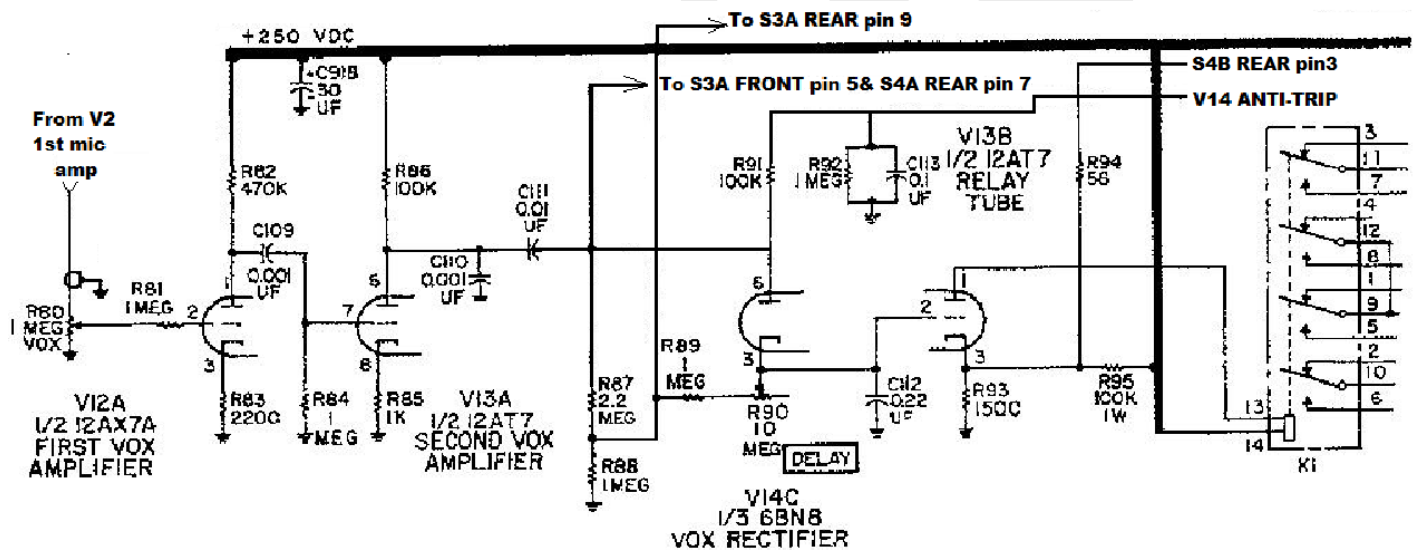

2-2-1, VOX TEST SETUP

Warm up in “safe” mode. Tune up in cw mode

- Set up; MOX, AM, MIC GAIN to 0, DELAY min, VOX (R80) to min. ANTI TRIP to min.
- Connect the microphone patch cable to J1 and the audio oscillator.
- Set audio oscillator to 1400Hz minimum output.
- With no audio input key up in mox, am and adjust T2 for 100 watts output.
- Set the MIC GAIN to 8. Monitor the RF carrier with the scope.
- Key the mic and increase the output of the audio oscillator until you have 95% modulation.
- Unkey, leave all settings and controls as they are this is the setup for 2-2-2 tests.

2-2-2, VOX TEST

In the following tests we will be switching between CW and AM. Insert an open phone plug into the KEY jack in the rear of the 44. This will open the key line in the CW mode. Switch to CW mode. The CW position will be the rest mode and AM will be the test and measurement mode. Audio at the proper level was established in 2-2-1.

- Switch to VOX, AM and advance VOX control R80 until the transmitter keys up. Switch to CW.
- Check the rotation of VOX control.
 - 1, Control in the center third of its rotation is normal.
 - 2, Control in the lower third of rotation indicates component drift or gassy tube in the VOX train.
 - 3, Control in the upper third of rotation indicates component drift or weak tube in the VOX train.
- Leave all controls on the HT-44 as they are for the next series of tests.

If the VOX fails to operate properly there is a fault in the vox train. Ensure the controls are set per 2-2-1 and proceed to 2-2-2-1. Once the fault is cleared return and complete 2-2-2.

2-2-2-1, VOX SIGNAL & VOLTAGE MEASUREMENTS

Turn the RF LEVEL to zero and with the rest of the controls set as per section 2-2-1 switch to VOX. Using the VOX control to key and unkey the unit. Make and record the following measurements.

MEASURED WITH SCOPE			MEASURED WITH DVM	
TIE POINT OF R80 & R81	V13A pin 7	V14C pin6	V13B p3 V14C p3	V13B pin 1
50 – 75mvpp	1.5 – 2.5 vpp	30vpp	0 / 15vdc *	305 / 169vdc *
NOTE * When VOX is operating correctly the first voltage is UNKEYED the second is KEYED.				

The first incorrect measurement is the location of the fault. Return to 2-2-2 when fault is cleared.

2-2-3, ANTI-TRIP

The anti-trip circuits are a sub-system of the VOX system. The purpose is to keep the receiver audio generated by the speaker from triggering the transmitter. A sample of the receiver audio is fed to the anti-trip circuit, processed and presented as a negative dc voltage proportional to the amplitude of the audio sample. This signal inhibits the VOX detector, V14C.

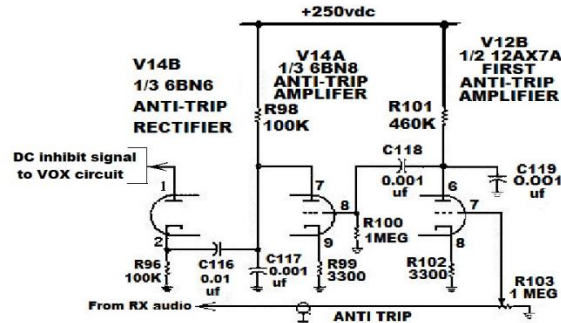

2-2-3-1 ANTI-TRIP TEST

Set up the transmitter in the safe mode. The anti-trip circuits are on all the time so the tests can be run without keying up the transmitter.

Dynamic test.

- Connect the audio oscillator and the scope to high side of R103 (ANTI-TRIP).
- Connect the DVM to pin 1 of V14.
- Adjust the audio oscillator output to 1400HZ and 3vpp as measured on the scope. You should hear the tone in the speaker in the power supply.
- Rotate R103 from end to end monitoring the voltage on pin 1 of V14.
- At the counter-clockwise end the voltage should be -0.2vdc.
- At the fully clockwise end the voltage should be at least -34vdc.

Gain test.

- Adjust ANTI-TRIP control for 1vpp signal on pin 7 of V12.
- Voltage on pin 8 of V14 should be 38vpp
- Voltage on pin 2 of V14 should be 100vpp
- DC voltage on pin 1 of V14 should be 25vdc

2-2-4 DRIVER/PA TROUBLESHOOTING

You will need a tube capacitive pickup adaptor for tests in this section. It can be constructed from an old tube shield *with the base cut off so that it does not contact chassis ground*. Pick a size that fits snugly over the 12BY7.



2-2-4-1 STATIC DC VOLTAGES

Set up in the safe mode, allow 10 minutes warm up. Switch from stby to MOX. Voltages are measured in the unkeyed condition.

	PIN 2	PIN 7	PIN 8
V8	-31VDC	295VDC	142VDC
V9	-35VDC	297VDC	297VDC

2-2-4-2 SIGNAL DRIVE LEVELS

Set up in the safe mode, allow 10 minutes warm up. Band 7.0.

- Set MIC GAIN and RF LEVEL to **minimum**.
- Remove V15 and V7.
- Inject 7.23 MHz

from signal generator into the tie point of C55 and L10. I use a 10X scope probe to inject the signal.

- Place the tube pick-up on V8 and connect the scope to it.

- With mic key transmitter and increase drive from generator to produce 0.5vpp on the scope. Some adjustment of the DRIVER and PLATE TUNE controls may be required

- If you cannot get 0.5vpp on V8 then the mixer stage has a fault. This fault must be cleared before you can proceed.
- Move the tube pic-up adaptor to V9 you should see 13 - 16vpp when the mic is keyed.
- If you did not get 13 -16vpp on the V9 pick-up then the driver stage has a fault. This fault must be cleared before you can proceed.
- With 16vpp on V8, you should have close to 100 watts output from the PA. If not, then the PA has a fault (**driver, plate, L8 and L18 may require slight adjustment**). If this test is successful go to 1-8-2.

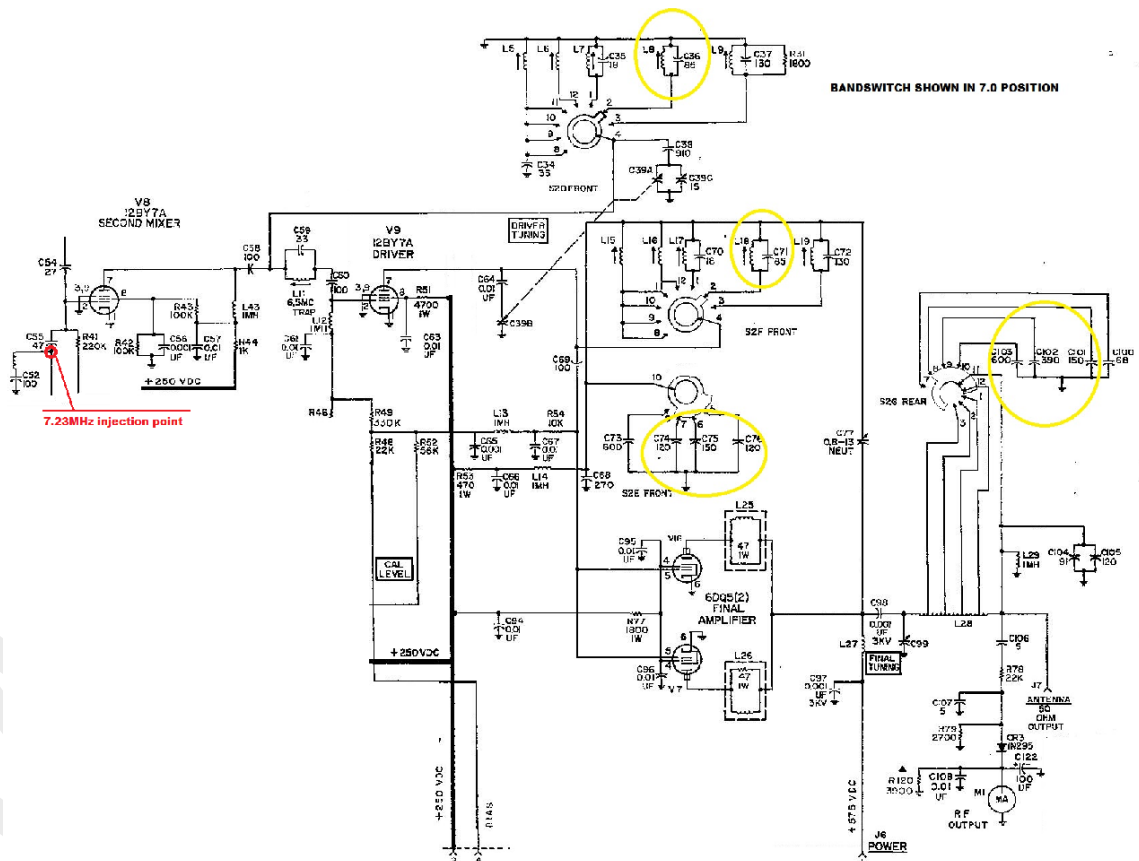

2-2-5 AALC

When a small amount of grid current occurs in the final amplifier, an audio signal appears on the bias line in proportion to the amount of grid current. This audio component is coupled to the AALC circuits for processing. The resulting DC voltage is fed as a gain control to V7, the 6Meg I.F. amp. The actual amount of AALC action varies from rig to rig. It is dependent upon the condition of the PA final tube, the gain of the second mixer and driver and the voltages from the power supply. If the AALC does not function check V7 and CR1 and CR2.

2-2-6, DRIVER TUNING SETPOINTS



Why worry about it? The mismatch of L and C in the circuit will eventually lead to oscillations in the driver or harmonics and spurs in the transmitter. Before we start ensure the knob is indexed correctly. Turn the knob until it hits the stop in counter clockwise direction and note the position of the pointer. Now reverse the direction to the stop and note the pointer position. If the two end points are not balanced from end to end you will need to loosen the set screws and reset the knob for balanced rotation.

NOTE: This same error will occur with the FINAL TUNING control. It is usually caused when L28 has been deformed by high VSWR heating. Getting the tuning back to where it should be usually requires a new L28 and optimizing C100, 101, 102, 103 and 104.

We will start with the 40-meter band.

- Band switch to 7.0. VFO to 230. DRIVER TUNING to center of 40 tab.
- In CW with telegraph key installed key up.
- Adjust FINAL TUNING for max power output.
- If there is no power output, you will have to tune and walk the control back to where it belongs.
- Adjust the DRIVER TUNING until you find the power peak.
- Peak the driver and final for max power. Using the RF LEVEL keep the power around 75 to 100 watts.
- Move the DRIVER TUNING knob slightly in the direction to the position where it should be maintaining at least 20 watts output.
- Adjust C39C, L8 and L18 for max power.
- Move the DRIVER TUNING again in the proper direction and readjust C39C, L8 and L18.
- Repeat until you have walked the DRIVER TUNING control back to where it should be.

You will repeat this procedure on the remaining bands. **BUT YOU WILL NOT RE-ADJUST C39C**

- On 80 meters set the VFO to 900 adjust L9 and L19
- On 20 meters set the VFO to 280 adjust L7 and L17
- On 15 meters set the VFO to 360 adjust L6 and L16
- On 10 meters band switch to 28.5, set the VFO to 750 adjust L5 and L15

Go to 1-8 and revisit the 10 through 80meter driver/PA alignment.

2-2-7, GOING ON THE AIR WITH THE 44

Everything should be in proper working order at this point. There are however 2 last readjustments that need to be done before you connect the antenna.

2-2-7-1, BIAS ADJUSTMENT

Set up and turn on the 44 in the safe mode. Allow at least 15 minutes for everything to come up to temperature.

- Ensure the RF LEVEL is set to zero.
- Turn the FUNCTION control to CW. You should see plate current on the plate current monitor meter.
- Adjust the BIAS ADJUST for 100ma of plate current.
- Return to the safe mode.

2-2-7-2, PA OUTPUT FINAL ADJUSTMENT

As stated before, the HT-44 is capable of much more than 130 watts output. However, the audio circuits were not designed to drive the system at higher power levels.

Set up and turn on the 44 in the safe mode. Allow at least 15 minutes for everything to come up to temperature.

- Tune up on 14.25MHz in CW mode.
- Connect the microphone patch cable.
- Set Operation control to USB.
- Set MIC GAIN to maximum.
- Set the audio oscillator to 1000Hz @ 3mv output.
- Key the mic.
- Adjust T2 for 130watts output.

That's it, get on the air and have some fun.

3, ATTACHMENTS

3-1, ERRATA SHEET TUBE MATCHING

ERRATA SHEET

MODEL HT-44

After the Instruction Manual was printed but prior to production certain electrical changes were made to improve the performance of this equipment. These changes are as follows:

1. Disregard the information contained in the parts list and schematic contained in the Instruction Manual. In their place substitute the schematic and parts list contained in this errata sheet.
 2. Disregard the information contained in paragraph 9-4 on pages 19 and 21 of your Instruction Manual. In its place substitute the following information:
- 9-4. FINAL (6DQ5) TUBE MATCHING.

If either or both 6DQ5 tubes are replaced, tube matching will be required. This may require access to a number of tubes in order to select those with the desired characteristics. Matched pairs of tubes are available through Hallicrafters' Service Department for customer convenience.

The procedure for tube matching the HT-44 is as follows:

CAUTION

It will be necessary to come into contact with circuits which normally have high voltage applied to them. Use extreme care while performing the following operations. Use a well-insulated screwdriver or other suitable tool to short the 6DQ5 plate caps to the chassis before making body contact with them.

1. Set the OPERATION switch at OFF.
2. Turn the four top cover retaining screws one-quarter turn counterclockwise and lift off the top cover.
3. Remove the top cover from the final amplifier cage.
4. Remove bottom cover of cabinet.
5. At the socket of V16, unsolder the orange lead from pin 4 (screen). Make certain this lead does not short to the chassis when the unit is turned back on to balance the tubes.
6. Connect a voltmeter or milliammeter to the power supply tip jacks as described in BIAS ADJUSTMENT, paragraph 9-3.
7. Set the OPERATION switch at STBY and allow approximately two minutes warmup.
8. Set the RF LEVEL control at 0.
9. Set the OPERATION switch at MOX.
10. Set the FUNCTION switch at CW.
11. Adjust the BIAS ADJ control for a 0.5-volt (50 MA) reading on the voltmeter.
12. Return the OPERATION switch to OFF.
13. Short the 6DQ5 plate cap to the chassis and remove the tube from its socket.
14. Insert a new 6DQ5 tube into the socket of V17 (the socket nearest the outside edge of the chassis).
15. Place the OPERATION switch in STBY and allow approximately two minutes for warmup.
16. Place the OPERATION switch in MOX and observe the voltmeter reading. (Do not change the bias setting.)
17. If this tube causes the voltmeter to read between 0.4 volt (40 MA) and 0.6 volt (60 MA), it can be considered as being matched to the original tube. If the difference in reading exceeds 0.1 volt (10 MA), other tubes must be checked until the difference reading of the pair to be matched is less than 0.1 volt (10 MA).
18. Reconnect the orange lead to pin 4 of V16.

NOTE

If both tubes are defective, both tubes should be removed. Then a new tube should be installed in each socket.

Printed in U.S.A.
364

Form Number 094-903794B
Pack with Instruction
Manual 094-903582

3-2, INTERNAL R/T RELAY MOD

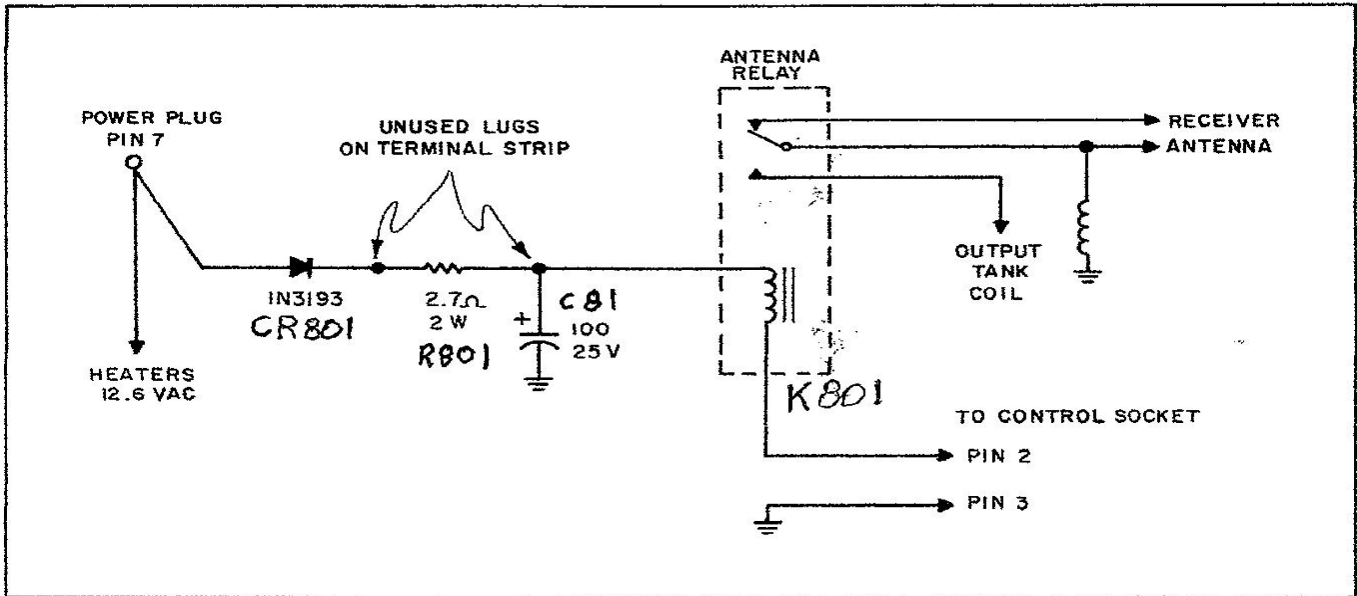

Figure 20. Partial Schematic, Showing Relay Installation.

156-002724

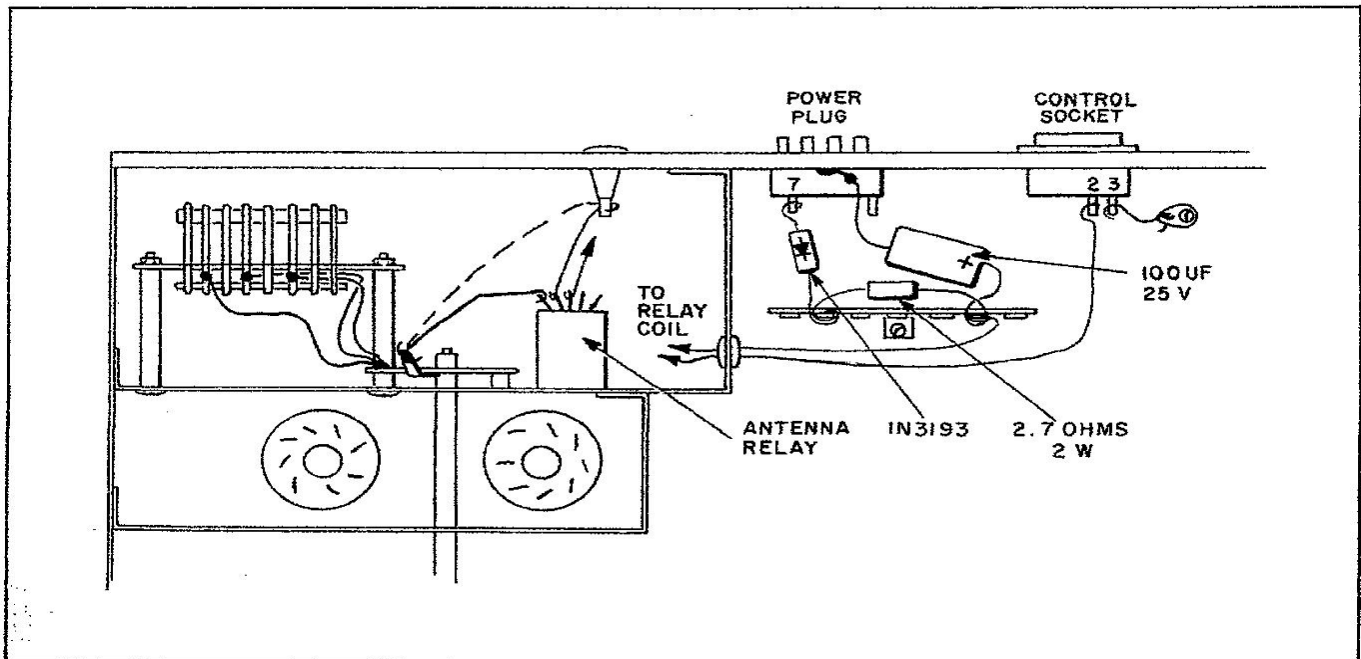
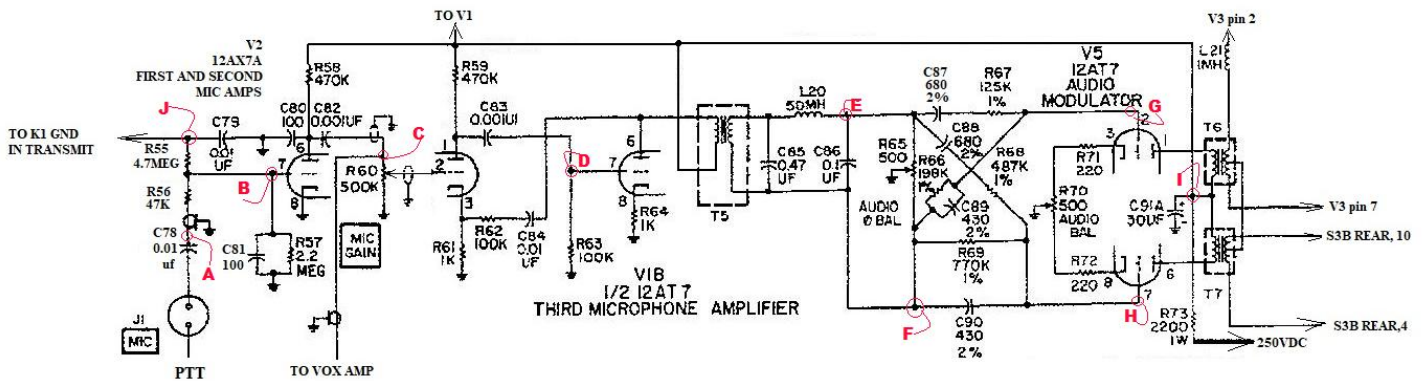

Figure 21. Partial View of HT-44, Showing Relay Installation.

156-002720

3-3, DATA SHEETS

3-3-1 MIC AUDIO DATA



VOLTAGE CHART

V2		V1B		V5	
1	57v/ (50v STBY)	5	260v/ (227 AM KEYED)	1	260v/ (227 AM KEYED)
2	0.0	7	0.0	2	0.0
3	0.34V	8	2.6V/ (3.0V STBY)	3	2.0
6	60v/ (160 STBY)	/	/	6	260v/ (227 AM KEYED)
7	-0.7V / (140V cw)	/	/	7	0.0
/	/	/	/	8	2.0
/	/	/	/		

SIGNAL LEVEL CHART

Measurement taken in MOX, AM, mic keyed, MIC GAIN @ max.

Inject 12mvpp, 1000Hz @ test point A.

B	C	D	E	F	G	H

Test point I

Test point J

3-3-2, VOX SIGNAL & VOLTAGE MEASUREMENTS

If at any time during this procedure the transmit power comes up to full remember to keep the transmit cycle short. With the equipment set as per section 2-2-1 we will switch to VOX and set the VOX control to the center of its rotation

MEASURED WITH SCOPE			MEASURED WITH DVM	
TIE POINT OF R80 & R81	V13A pin 7	V14C pin6	V13B p3 V14C p3	V13B pin 1
50 – 75mvpp	1.5 – 2.5 vpp	30vpp	0 / 15vdc *	305 / 169vdc *

NOTE * When VOX is operating correctly the first voltage is UNKEYED the second is KEYED.

Return to 2-2-2 when fault is cleared

3-3-3, CARRIER OSC

MODE / VOLTAGE CHART

OPERATION	FUNCTION	R1 – R2	R2 bottom	V1pin1	V1 pin2	V1 pin3
MOX	AM	-138vdc	-140	265vdc	-130vdc	0.0vdc
MOX	CW	-1.4vdc	0.0vdc	199vdc	0.0	3.0vdc

NOTES: Some schematics have R2 listed as C2. Voltages will differ from rig to rig. In the rig used for these readings the 250vdc measured 313vdc, the bias measured -140vdc.

3-3-4 HET OSC

HET OSC VOLTAGE CHART

FUNCTION	OPERATION	V15					
		PIN 1	PIN 2	PIN 3	PIN 6	PIN 7	PIN 8
MOX	AM	144	0	0	302	57	53

3-3-5 VFO

VFO VOLTAGE CHART

OPERATION	FUNCTION	V10						
		PIN 1	PIN 2	PIN 3	PIN 6	PIN 7	PIN 8	PIN 9
MOX	AM	141vdc	0	86	141*	0	4	0

*Measured at junction of L2 & R24

3-3-6, MIXER-IF

MIXER/IF VOLTAGE CHART

V6		V7		V8	
PIN	VOLTAGE	PIN	VOLTAGE	PIN	VOLTAGE
1	0	2	0	2	-144/-0.5
2	1.0 *	3	83/73	7	317/276

5	317/277	6	1.1/0.9	8	158/57
6	61/53 *	7	317/274		
7	0				

Voltages with * will differ dependent upon band selection.
 Measured in MOX, AM. First voltage **unkeyed**/second voltage **keyed**.

3-4 MISC

3-4-1, ANALYZER/SCOPE PICKUP

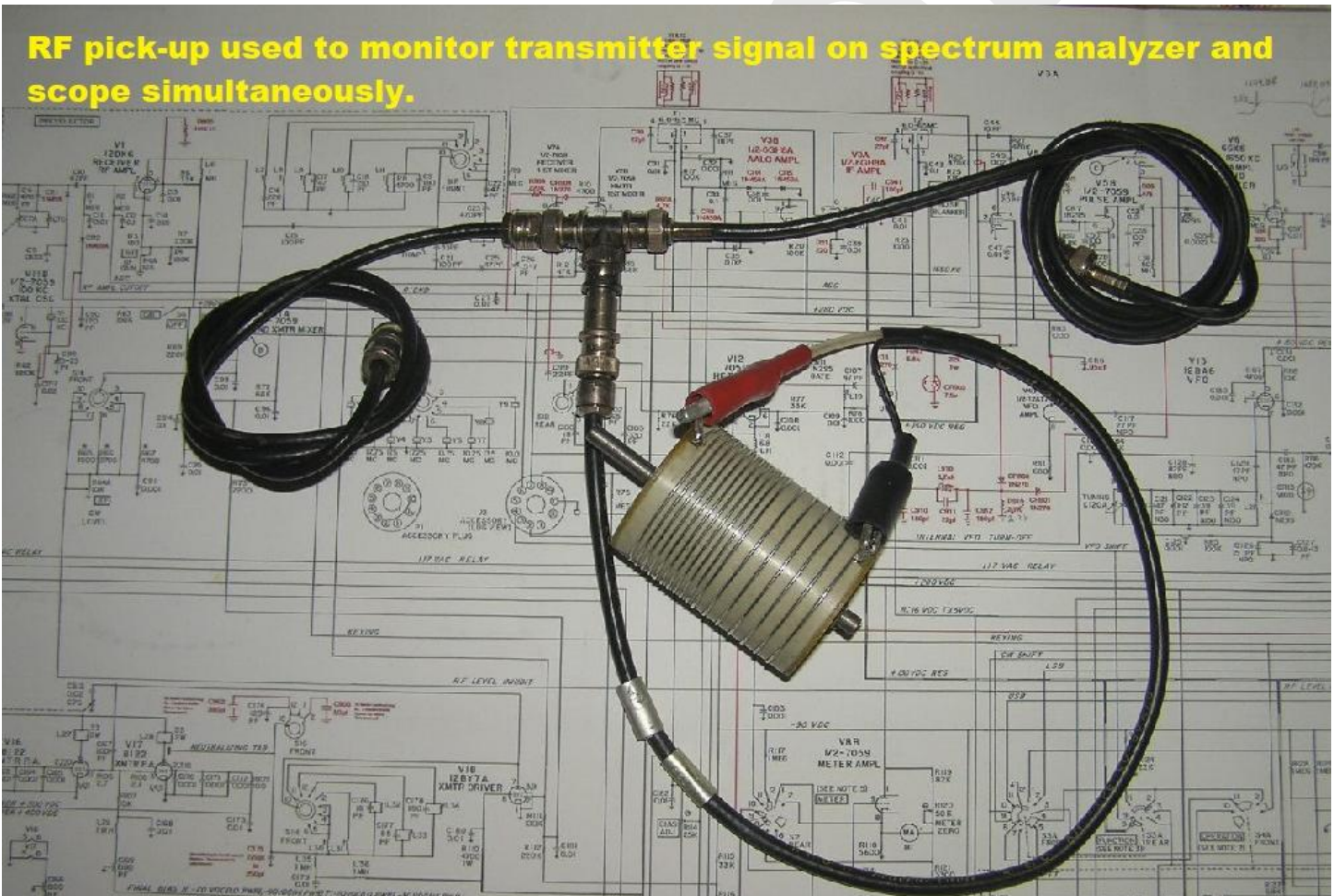

WDOGOF

SEE MORE @ WDOGOF.COM

WDOGOF